

PN16 Ductile Iron Double Regulating Valve (DRV)

Features

- Flange Mounting PN16 Only
- Flange conforms to BS EN1092 PN16
- Position indicator
- Double regulating device
- Supplied with 2 test points and extensions
- EPDM cone seating gives tight shut off
- Body ductile iron
- Conforms to BS 5152 / BS 7350



Pressure/Temperature

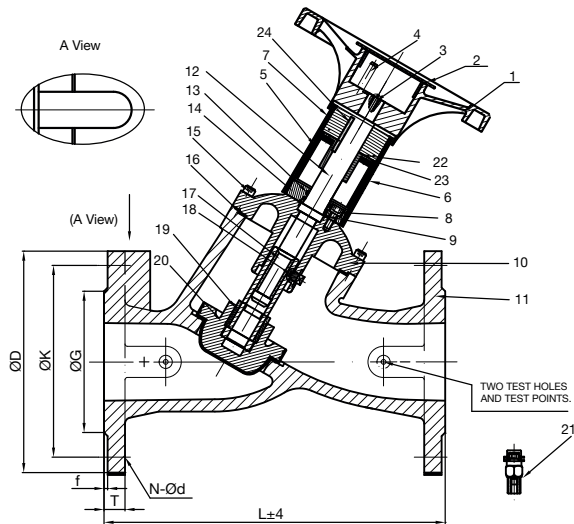
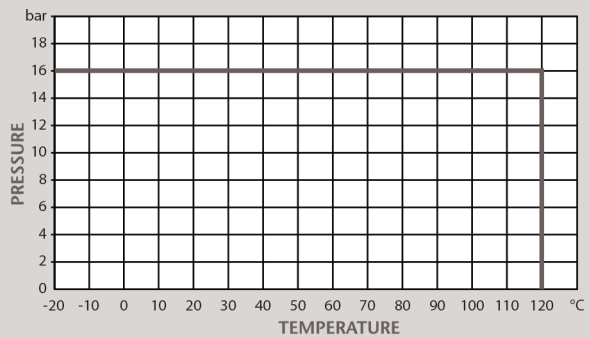

Technical Data

Max Pressure	16 Bar
Working Temperature	-20°C to +120°C

Dimensions in mm

This data sheet is designed as a guide and should not be regarded as wholly accurate in every detail. We reserve the right to amend the specification of any product without notice.

DN	50	65	80	100	125	150	200	250	300
D	165	185	200	220	250	285	340	405	460
K	125	145	160	180	210	240	295	355	410
n-d	4-19	4-19	8-19	8-19	8-19	8-23	12-23	12-28	12-28
T	19	19	19	19	19	19	20	22	24.5
G	99	118	132	156	184	211	266	319	370
f	3	3	3	3	3	3	3	3	4
L	230	290	310	350	400	480	600	730	850
A	370	430	440	470	520	570	730	830	950
Kvs	48.2	82.6	117.4	211.4	381.5	462.4	790	1135	2022
Kgs	12.4	15.8	20.8	29.8	41.7	55.6	125.5	194	288

N.	Part Name	Materials
1	Handwheel	Aluminium Alloy / Steel
2	Handwheel Cover	Plastic
3	Handwheel Lock Screw	Stainless Steel 304
4	Adjusting Screw	Stainless Steel 304
5	Indication Tube	Plastic
6	Transparent Scale	Plastic
7	Connection Tube	ABS Plastic
8, 15	Hexagon Socket Screw	Carbon Steel
9, 13	O-Ring	EPDM
10	Cover	Cast Iron
11	Body	Ductile Iron
12	Stem	Stainless Steel 410
14	Packing Gland	Stainless Steel 410
16	Graphite Gland	Graphite
17	Stem Nut	HPb59-1
18	Positional Screw	Stainless Steel 304
19	Nut Cover	HPb59-1
20	Disc wrapped in Rubber	Cast Iron + EPDM
21	Test Points	
22	Drive Plate	Stainless Steel 410
23	Screw	Carbon Steel
24	Flat Key	Stainless Steel 410